

TriStar MOSFET Repair Instructions

Morningstar Corporation

Columbia, MD USA

This document outlines the procedures necessary to replace defective MOSFETS on the TriStar charge controller. Refer to the *TriStar Testing Document* for troubleshooting. These instructions assume that the TriStar has been completely removed from the system. Remove all wiring and conduit connections before proceeding. This document is for qualified technicians. Exercise caution when working with live circuits in PV systems.

Tools Required:

Digital multimeter

Needle-nose pliers, small

Wire cutters, small

Philips-head screwdriver (#1 size)

Small flat-head screwdriver (1/8" size)

Soldering iron, solder, solder wick

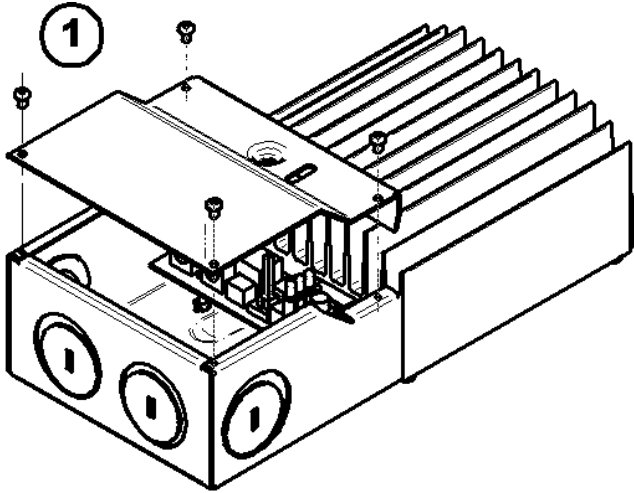

Remove the Cover Plate

Remove the four pan head screws that secure the wiring compartment cover. Remove the cover.

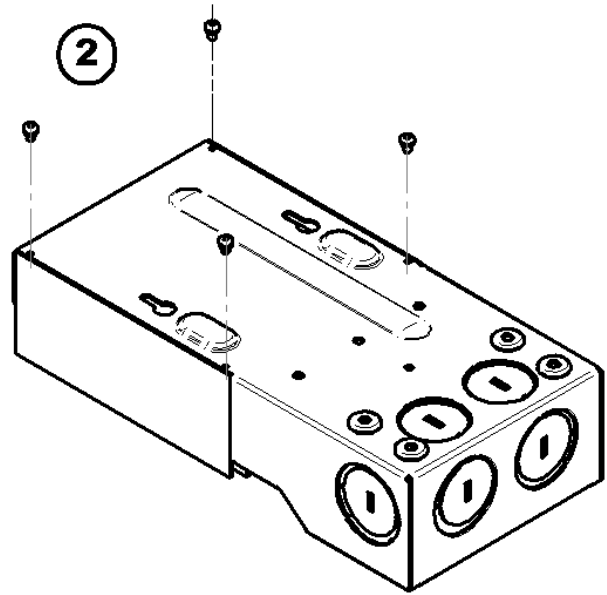

Remove Heatsink Screws

On the bottom of the TriStar, there are 4 screws that secure the heatsink to the sheet metal tray. Remove these four screws.

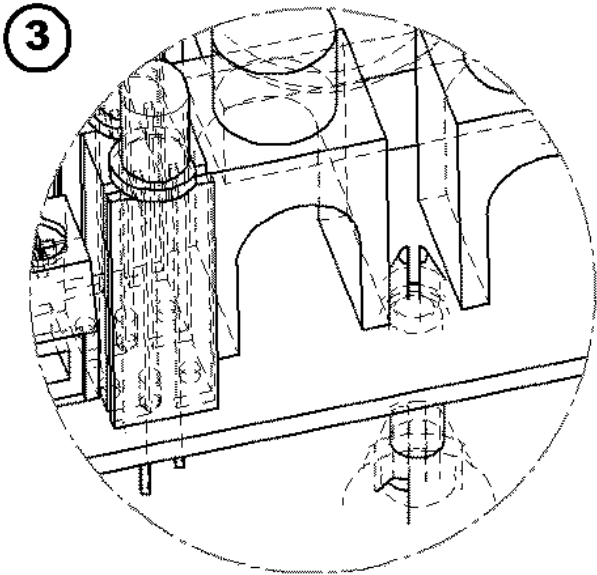

Separate Stand-offs

Two snap-in stand-offs support the PCB. Using a small flat-head screwdriver, gently pry the snaps and separate the PCB from the stand-offs.

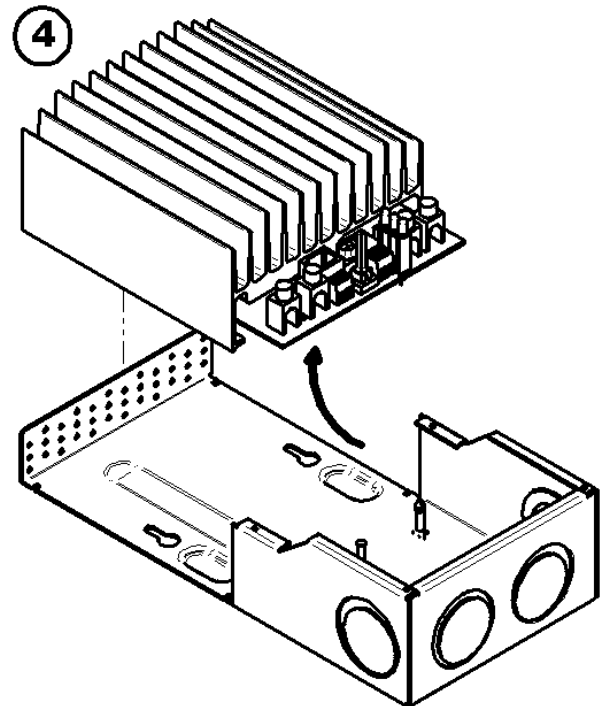

Remove Heatsink-PCB Assembly

Gently remove the heatsink and PCB assembly from the sheet metal tray. You may have to angle the assembly to clear flanges on the tray.

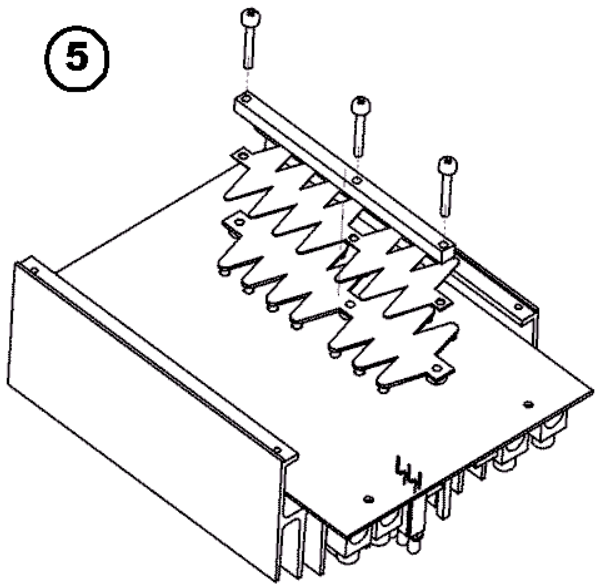

Remove Spring Screws

Remove the three screws that secure the spring assembly to the PCB and Heatsink. Unscrew the three screws in increments so that pressure on the bar is released evenly.

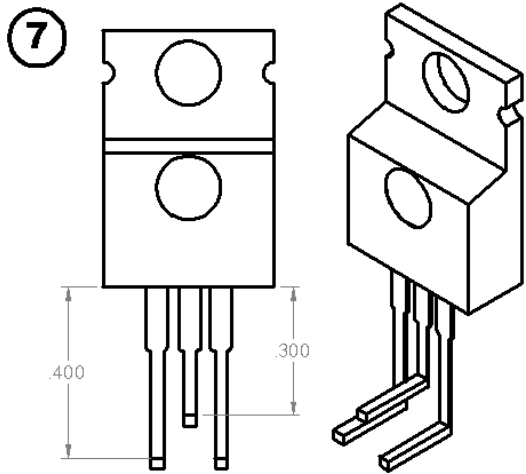

Form MOSFET legs

Caution: MOSFETS are ESD sensitive devices. Take precautions to avoid static shock when handling.

Using needle-nose pliers, bend the replacement MOSFET legs as shown in the diagram. (all units in inches)

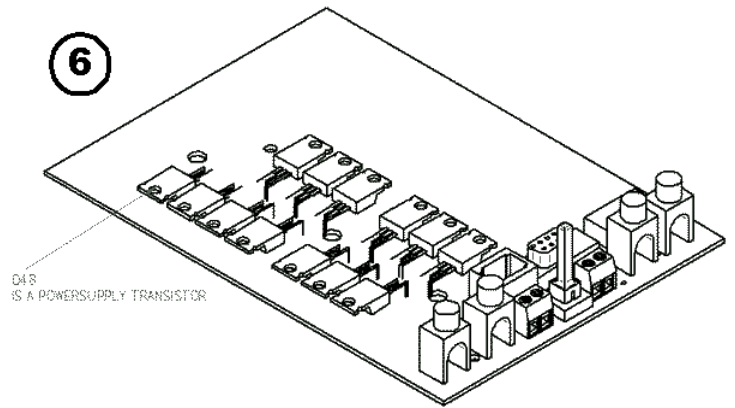

Remove Defective MOSFETs

The power MOSFETs are mounted on top of the board. A transistor for the power-supply, indicated in the diagram, is also mounted.

The TS60 has 12 MOSFETs

The TS45 has 6 MOSFETs. Clip off and remove the defective MOSFET(s). Clear solder and MOSFET leads from the PCB holes.

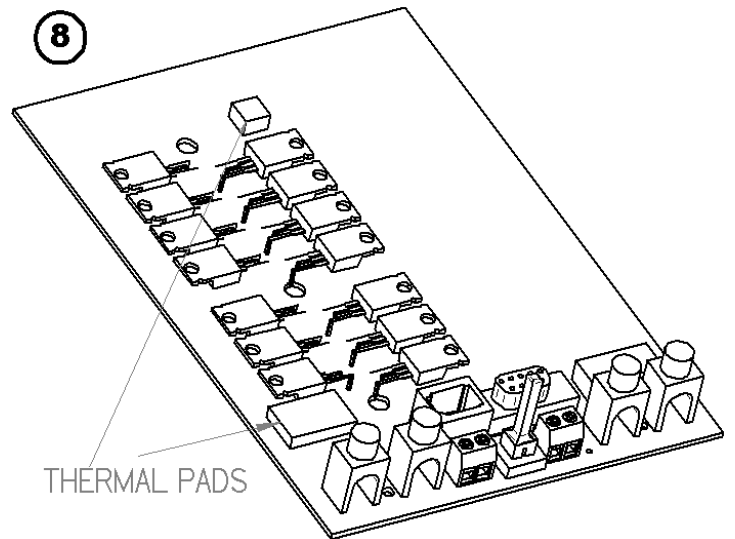

Solder Replacement MOSFETS

Insert replacement MOSFETs where defective MOSFETs were removed. Be sure that the MOSFET body sets level and flush with the PCB surface. Use other MOSFETs as reference. Solder MOSFET leads. **IMPORTANT!**

Before re-assembly, verify that the shunt and thermistor thermal pads are in place as shown in the diagram. One pad is placed on "RT1", the other is placed on the shunts, "RS1 - RS4"

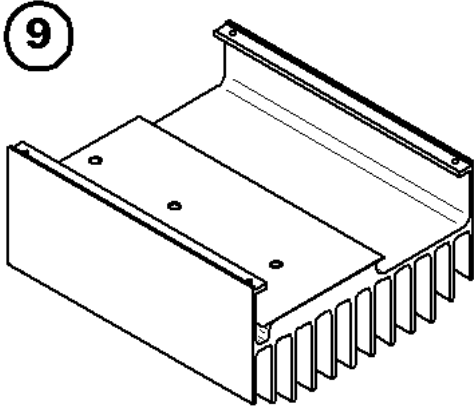

Inspect Thermal Pad and Re-assemble

Inspect the MOSFET thermal pad for rips, punctures, or tears. Verify that the pad will electrically isolate the MOSFETs from the heatsink. Smooth out any air bubbles.

Using the previous steps as a reference, re-assemble the TriStar.